



## GENERAL INFORMATION

1. Doors and frames will be reinforced for surface applied hardware. Gages of reinforcements will meet or exceed the gages as recommended by NAAMM and The Steel Door Institute. Drilling and tapping for surface applied hardware will be done by others. Doors and frames will be prepared for mortise hardware with holes drilled and tapped at factory excepting trim mounting holes.
2. All doors and frames will be coated with one coat of paint primer baked on at the factory following phosphate cleansing.
3. Refer to detail sheets attached for anchorage, jamb profiles, and frame elevations.
4. Furnishing and installation of glass and builders hardware to be by others.
5. Hardware locations on these drawings are to the manufacturers standard locations and relevant to standard hardware types. Non-standard locations must be confirmed prior to manufacture of products required.



# Door Specifications

Series	Type	Gauge	Core	CR/GALV	Edge	Handing	Thickness	Label	Max Size
1000	Flush	16, 18, 20	Polystyrene	CR/GALV	Corner Seam	Reversible	1 3/4"	3hr/PP/S	8'0 x 8'0
1100	Flush	16, 18, 20	Polystyrene or Honeycomb	CR/GALV	Lock Seam	Reversible or Handed	1 3/4"	3hr/PP/S	8'0 x 8'0
1200	Flush	20	Polystyrene	CR/GALV	Seamless	Reversible	1 3/4"	3hr/PP/S	8'0 x 8'0
1300	Stiffened	18	Mineral Wool Fill	GALV	Seamless	Handed	1 3/4"	3hr/PP/S	8'0 x 8'0
1400	Stiffened	16	Mineral Wool Fill	GALV	Seamless	Handed	1 3/4"	3hr/PP/S	8'0 x 8'0
MD1400	Max Duty	14	Polystyrene	GALV	Seamless	Reversible	1 3/4"	90 mins	4'0 x 8'0
WS1400	Wind Storm	14	SS	GALV	Seamless	Reversible	1 3/4"	90 mins	4'0 x 8'0
1500	Retrofit Replacement	18	Polystyrene	CR	Corner Seam	Reversible	1 3/4"	N/A	
1600	Flush	16	Polystyrene	GALV	Seamless	Reversible	1 3/4"	3hr/PP/S	8'0 x 8'0
1700	6-Panel	18, 20	Polystyrene	CR/GALV	Seamless	Reversible	1 3/4"	3hr/PP/S	3'0 x 8'0
1800	Flush	18	Polystyrene	CR/GALV	Seamless	Reversible	1 3/4"	3hr/PP/S	8'0 x 8'0
1900	2-Panel	18	Polystyrene	CR/GALV	Seamless	Reversible	1 3/4"	3hr/PP/S	3'0 x 8'0
2000	Flush	18	Honeycomb	CR/GALV	Seamless	Reversible	1 3/4"	3hr/PP/S	8'0 x 8'0
6000	Flush	18	Double Egress Honeycomb	CR/GALV	Seamless	Reversible	1 3/4"	3hr/PP/S	8'0 x 8'0
9000	Temp. Rise 250 Degrees	18	Mineral core	CR/GALV	Seamless	Reversible	1 3/4"	3hr/PP/S	8'0 x 8'0

CR: Cold Rolled, PP: Positive Pressure, GALV: Galvanized, S: Smoke

## Door and Frame Locations

### Standard Hardware Locations 4-1/2" Hinge

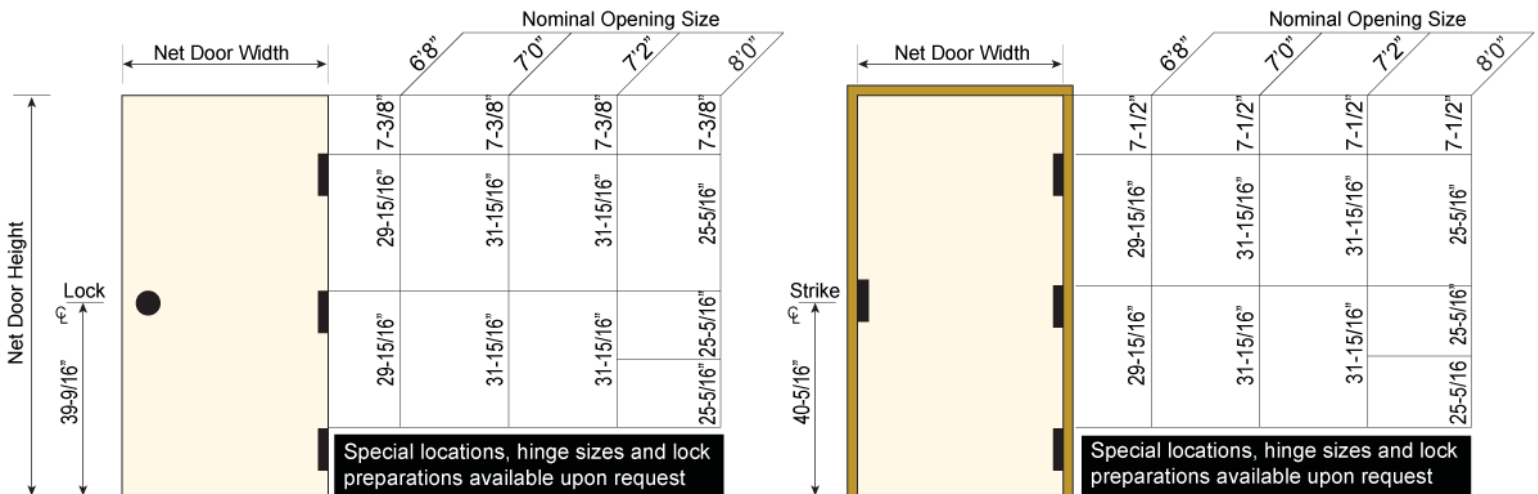

# Special Glass Size All Door Types

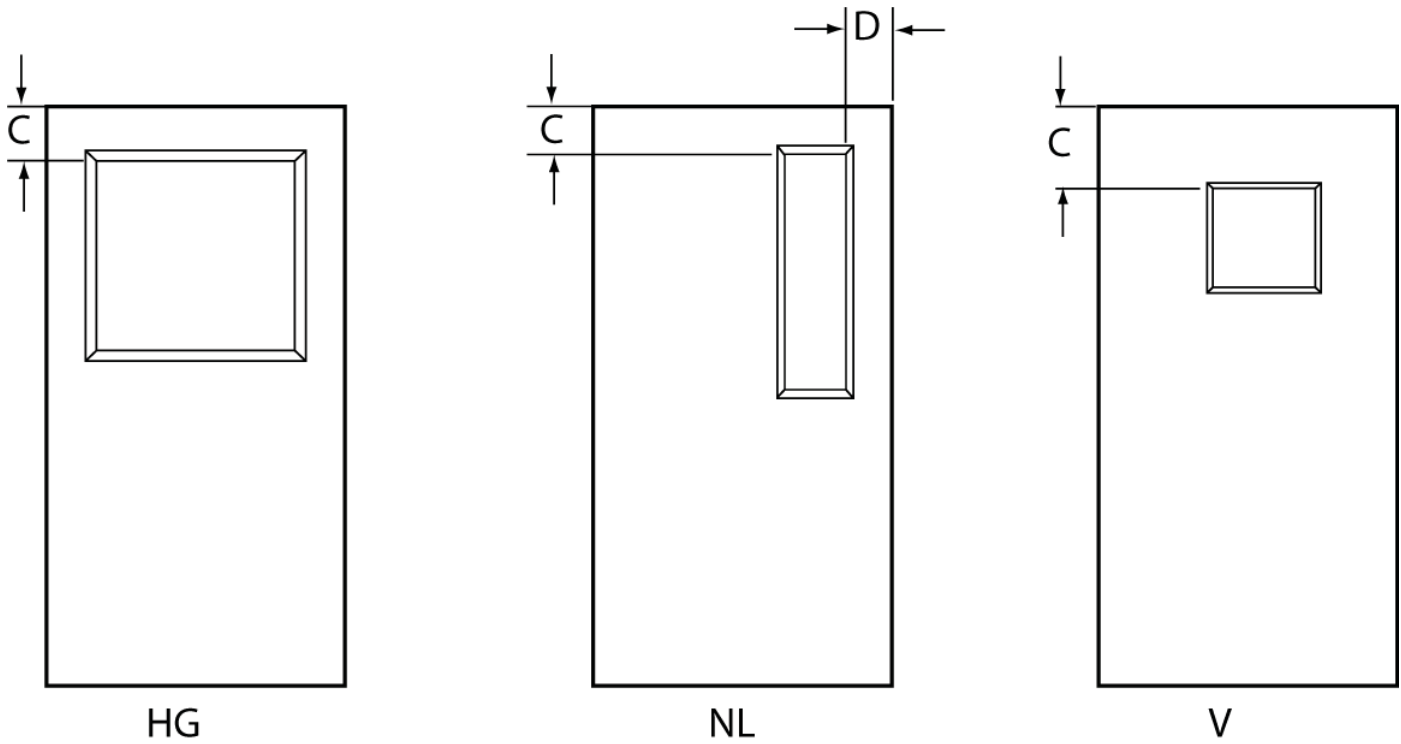
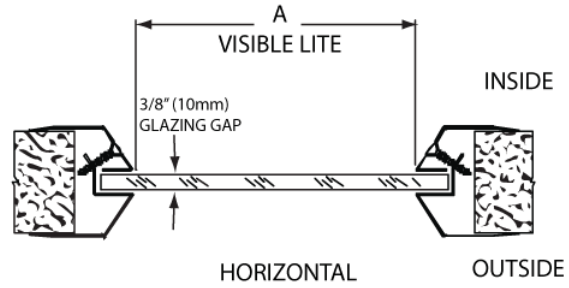
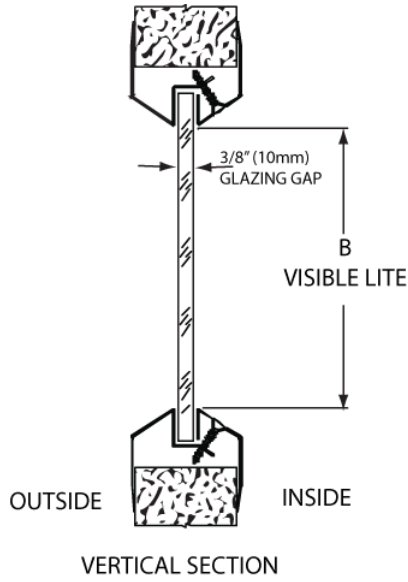

	A	B	C Top Rail	D Lock Stile
HALF GLASS				●
NARROW LITE				
VISION LITE				●

# Glass Lites Location Sheet

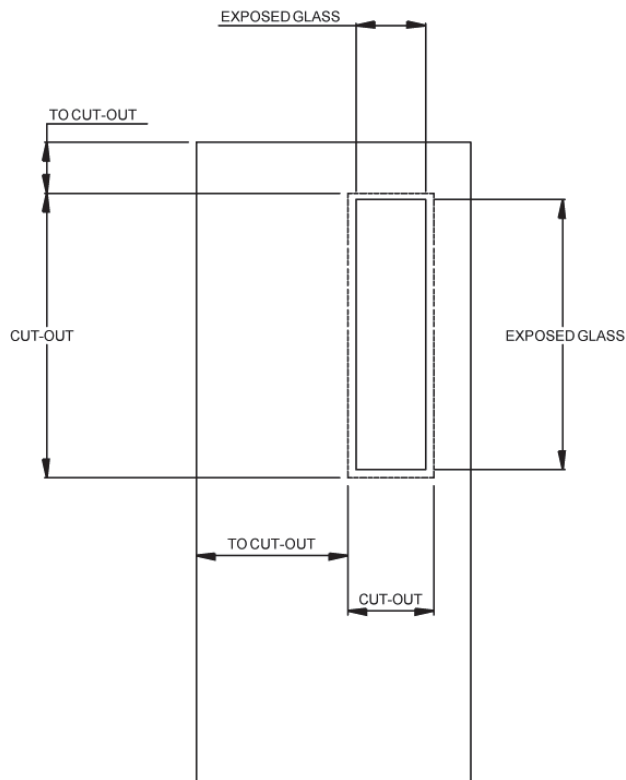
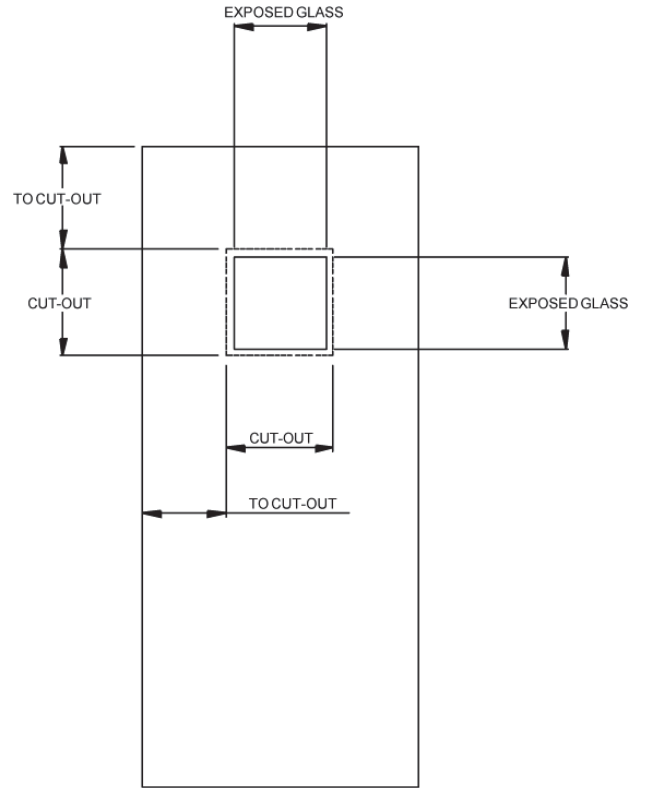
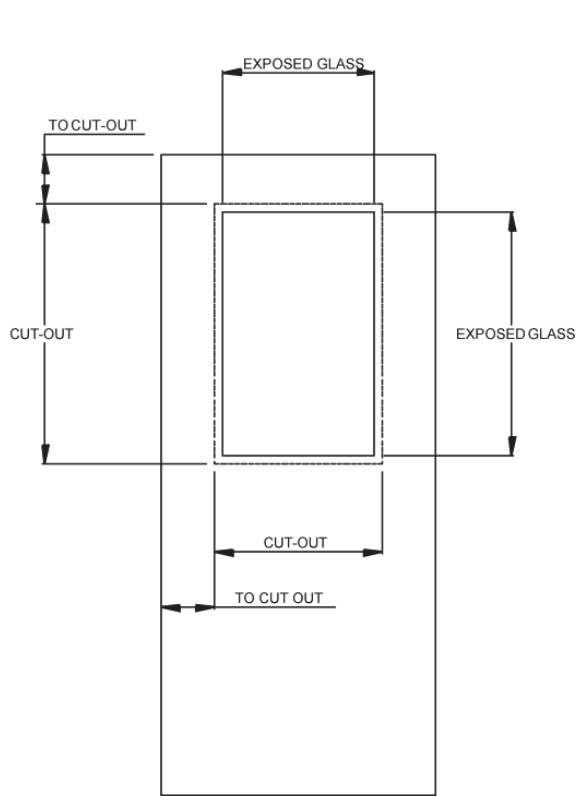

# Frame Profiles

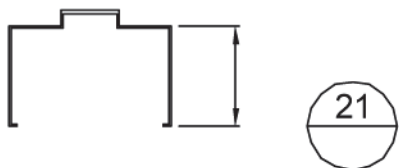
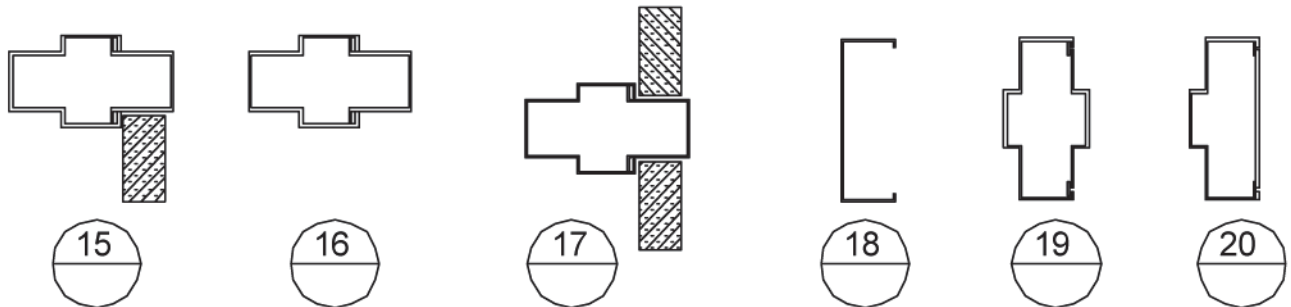
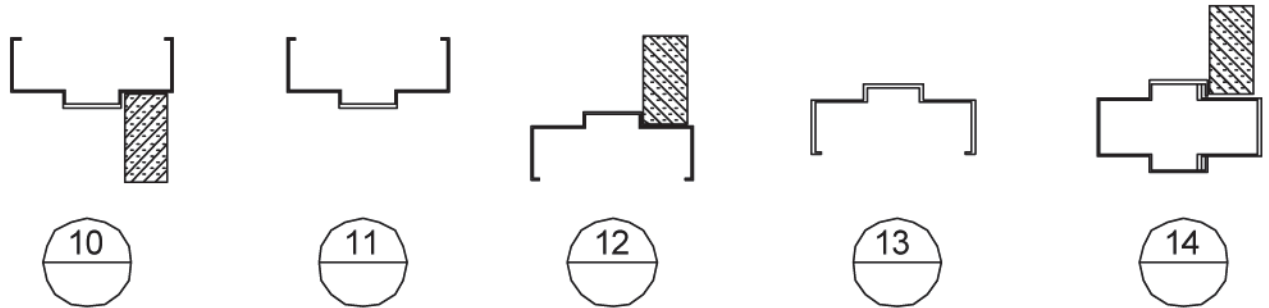
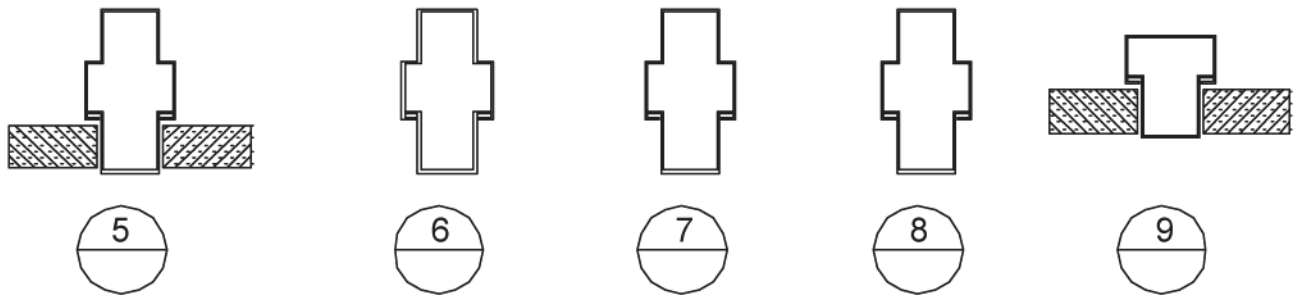
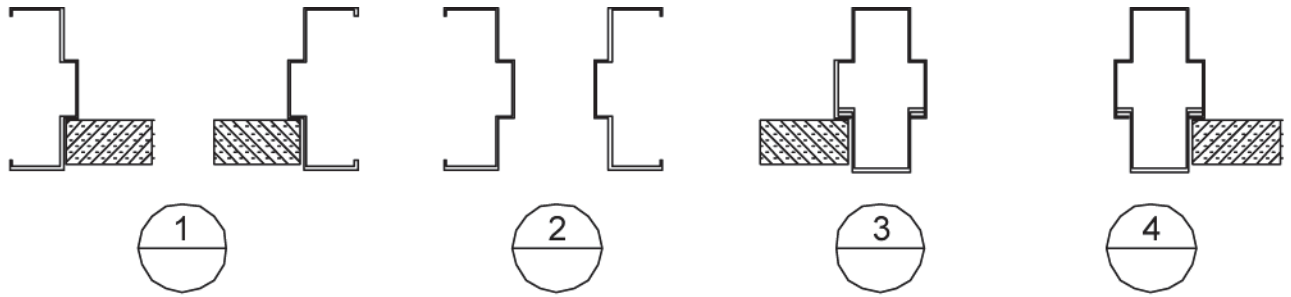

# Frame Elevations

---

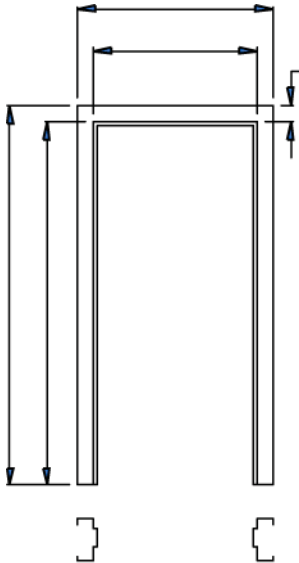

ELEVATION\_\_\_\_  
SINGLE FRAME

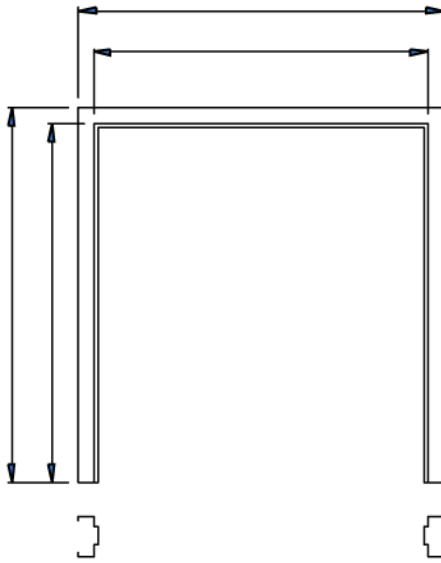

ELEVATION\_\_\_\_  
DOUBLE FRAME

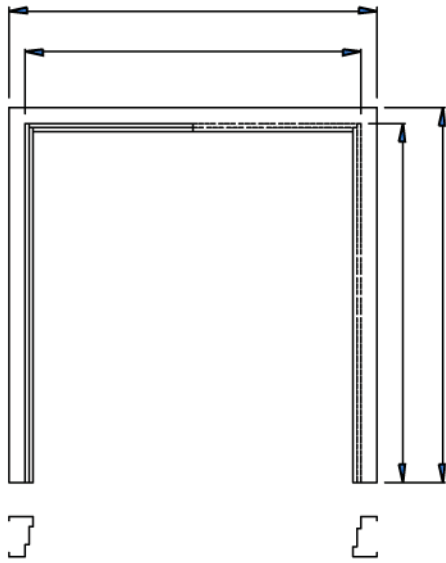

ELEVATION\_\_\_\_  
DOUBLE EGRESS FRAME

# Frame Elevations

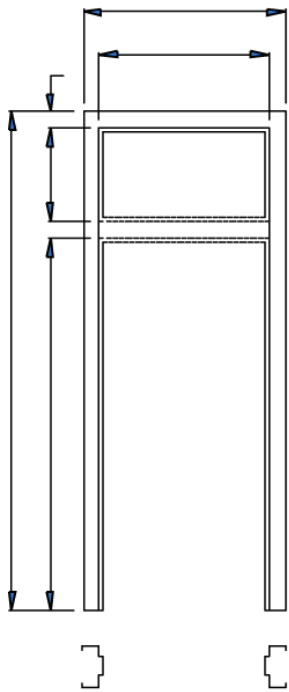

ELEVATION \_\_\_\_

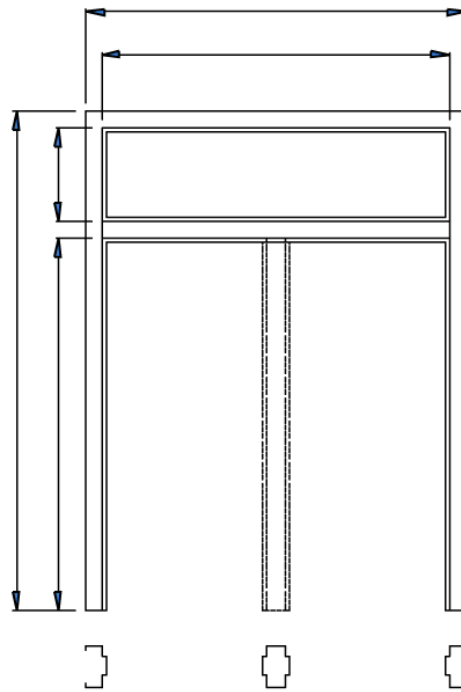

ELEVATION \_\_\_\_

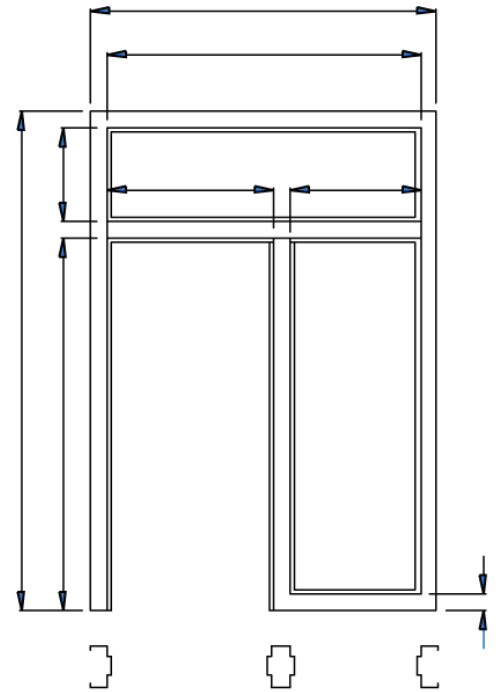

ELEVATION \_\_\_\_

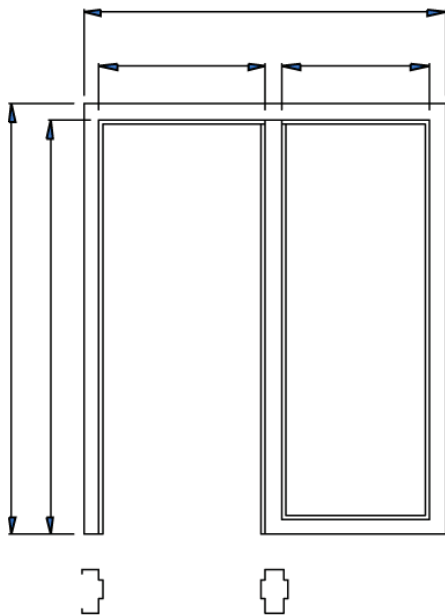

ELEVATION \_\_\_\_

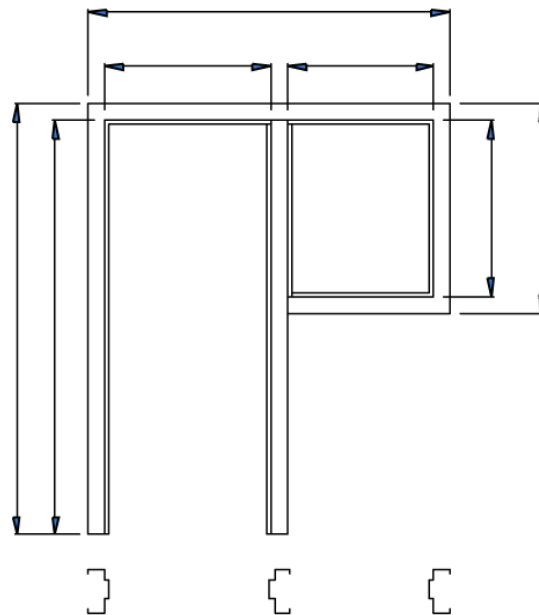

ELEVATION \_\_\_\_

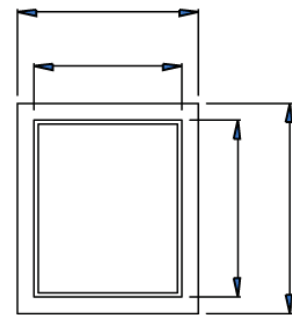

ELEVATION \_\_\_\_

**Door Swing  
& Glass side**



# Borrowed Lite Elevations

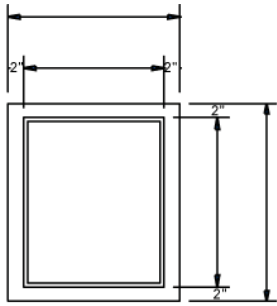

ELEVATION    A  
8 W.S. ANCHORS

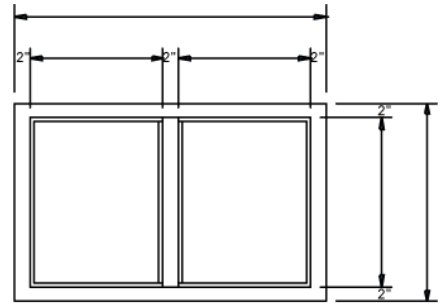

ELEVATION    B  
8 W.S. ANCHORS

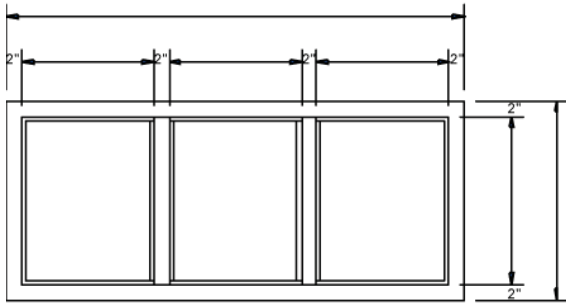

ELEVATION    C  
10 W.S. ANCHORS

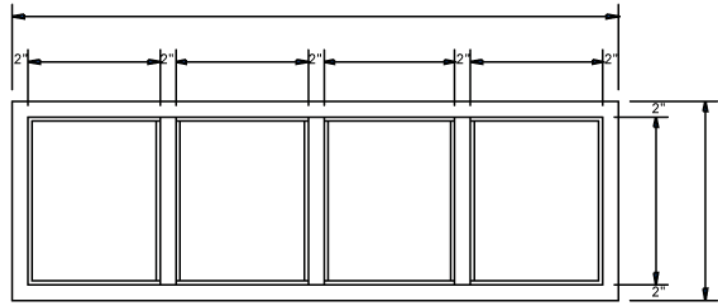

ELEVATION    D  
12 W.S. ANCHORS

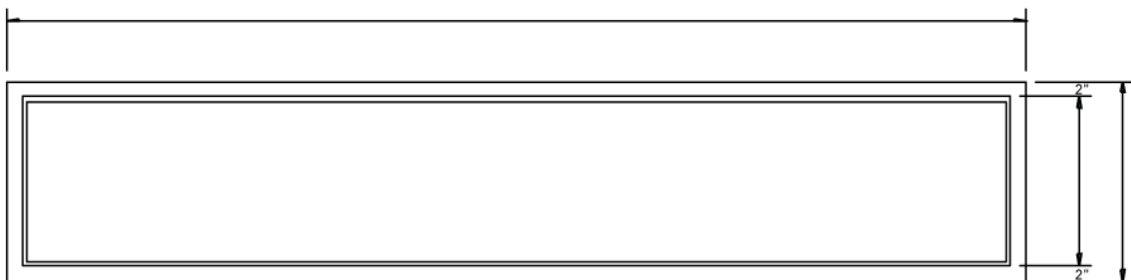

ELEVATION    E  
10 W.S. ANCHORS



# Anchors/Wall Conditions

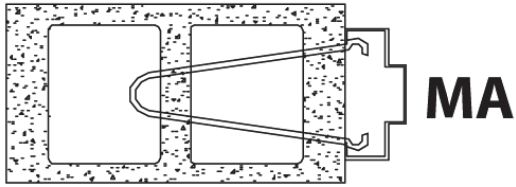

**MA**

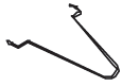

WIRE MASONRY ANCHOR  
3" THRU 8 3/4"  
(STANDARD)  
SPECIFY "MA"

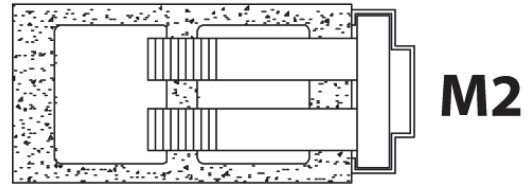

**M2**

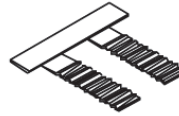

MASONRY ANCHOR  
9 1/2" AND OVER  
(OPTIONAL)  
SPECIFY "M"

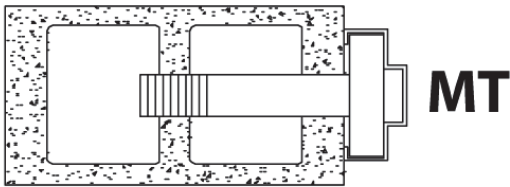

**MT**

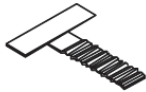

MASONRY ANCHOR  
UNDER 9 1/2"  
(OPTIONAL)  
SPECIFY "MT"

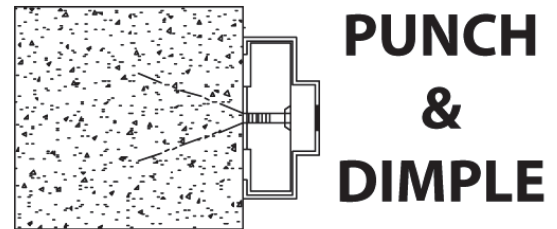

**PUNCH  
&  
DIMPLE**

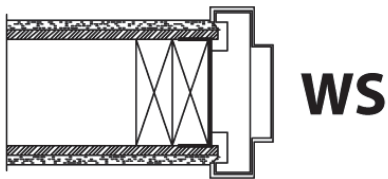

**WS**



WOOD STUD ANCHOR  
3 3/4", 4 3/4", 5 3/4", 6 1/4"  
6 3/4", 7 3/4", 8 1/4", 8 3/4"  
(STANDARD)  
SPECIFY "WS"

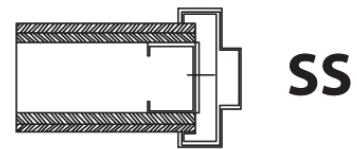

**SS**



STEEL STUD ANCHOR  
(STANDARD)  
SPECIFY "SS"

# 1000, 1100, 1200, 1600, 1700, 1800, 1900 Series

## Polystyrene Core 1 3/4" Doors

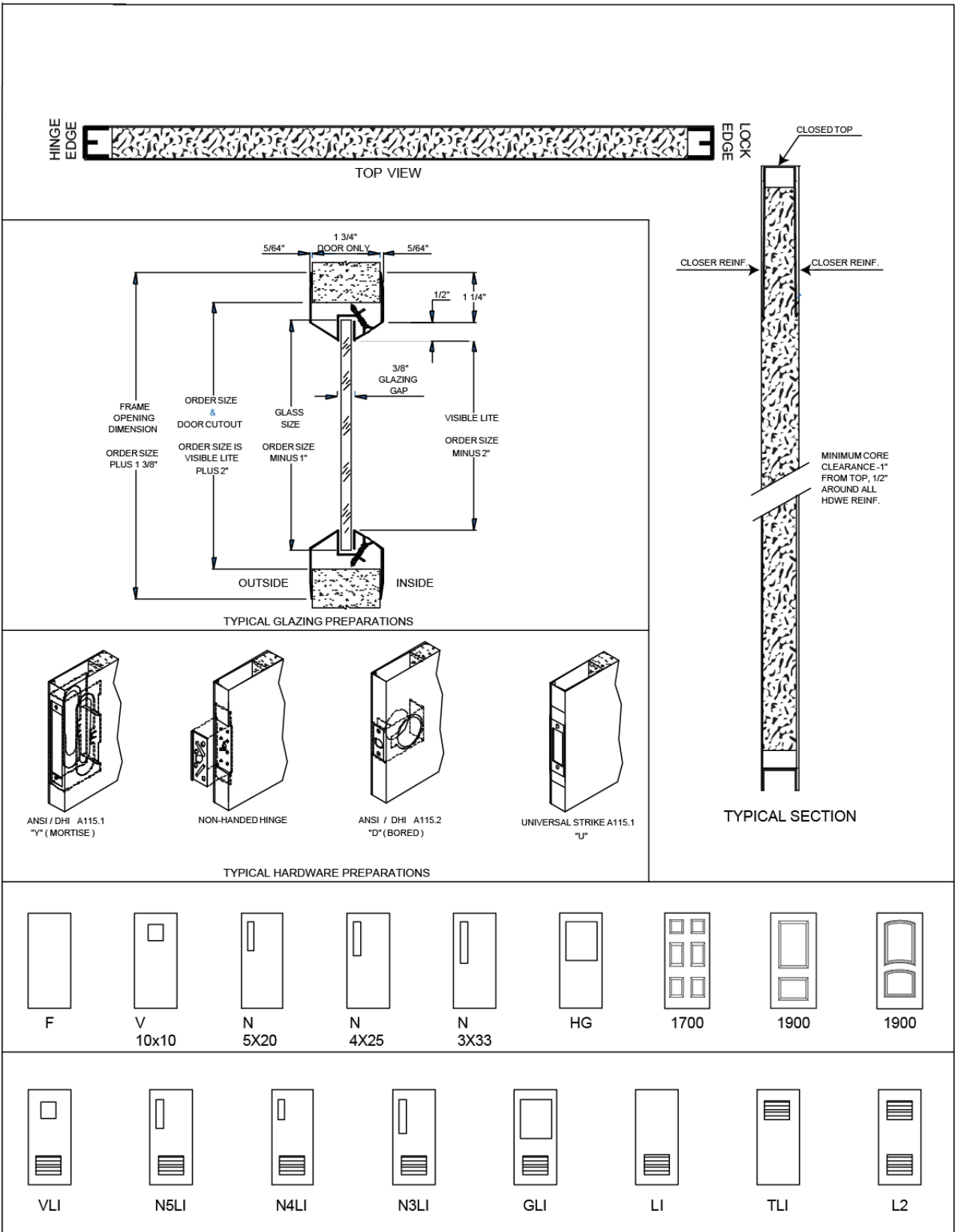

# 1900 Series 2 Panel Doors

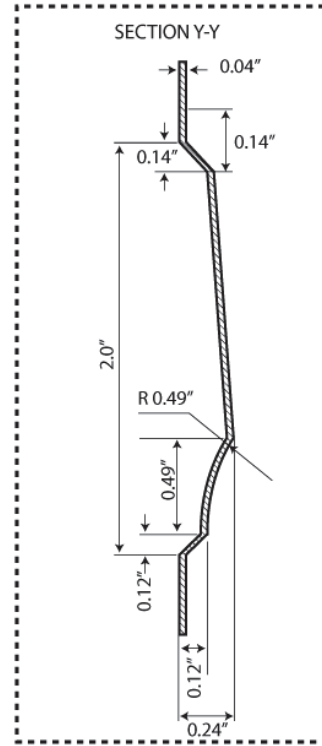
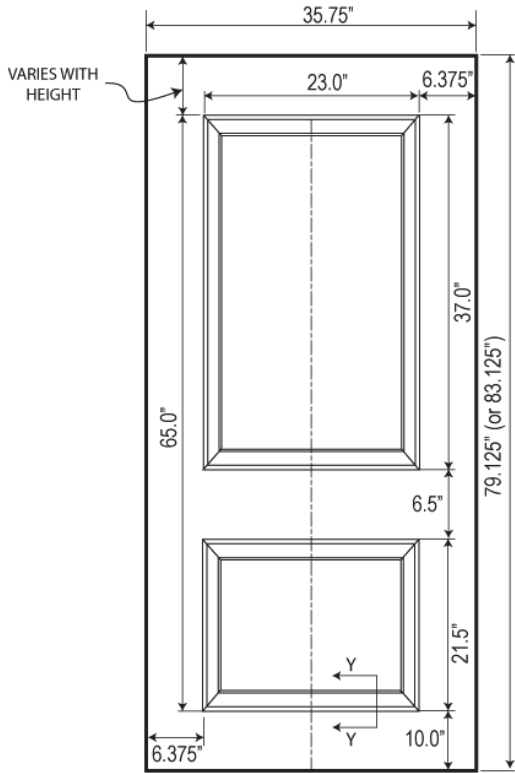

# 1700 Series 6'8", 7'0", 8'0" 6 Panel Doors

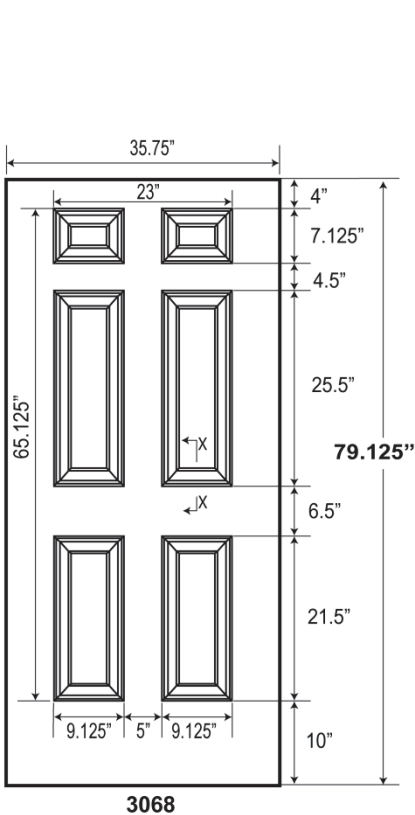

3068

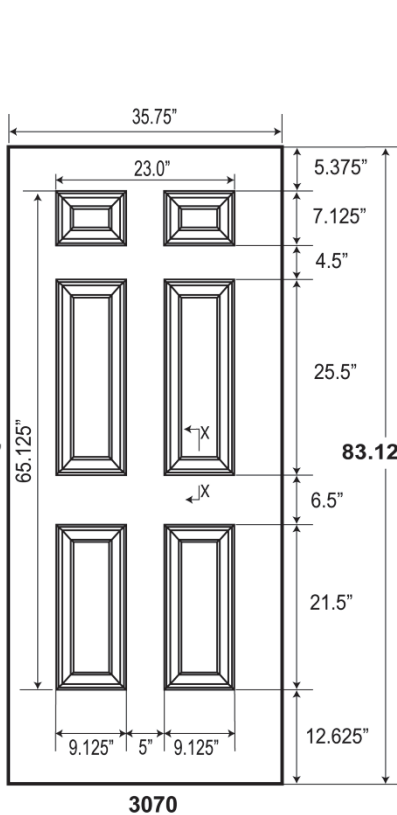

3070

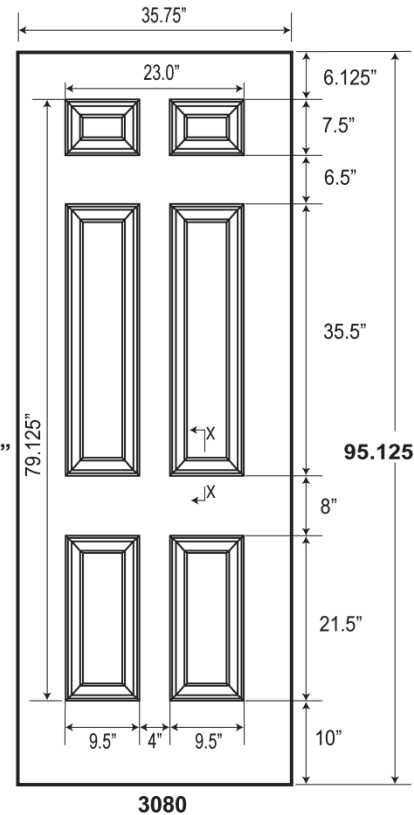

3080

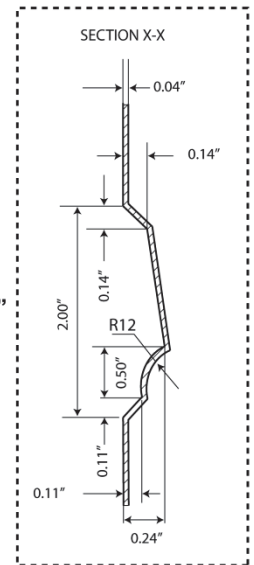

# 1900 Series 2 Panel Doors

## Steel Stiffened Doors

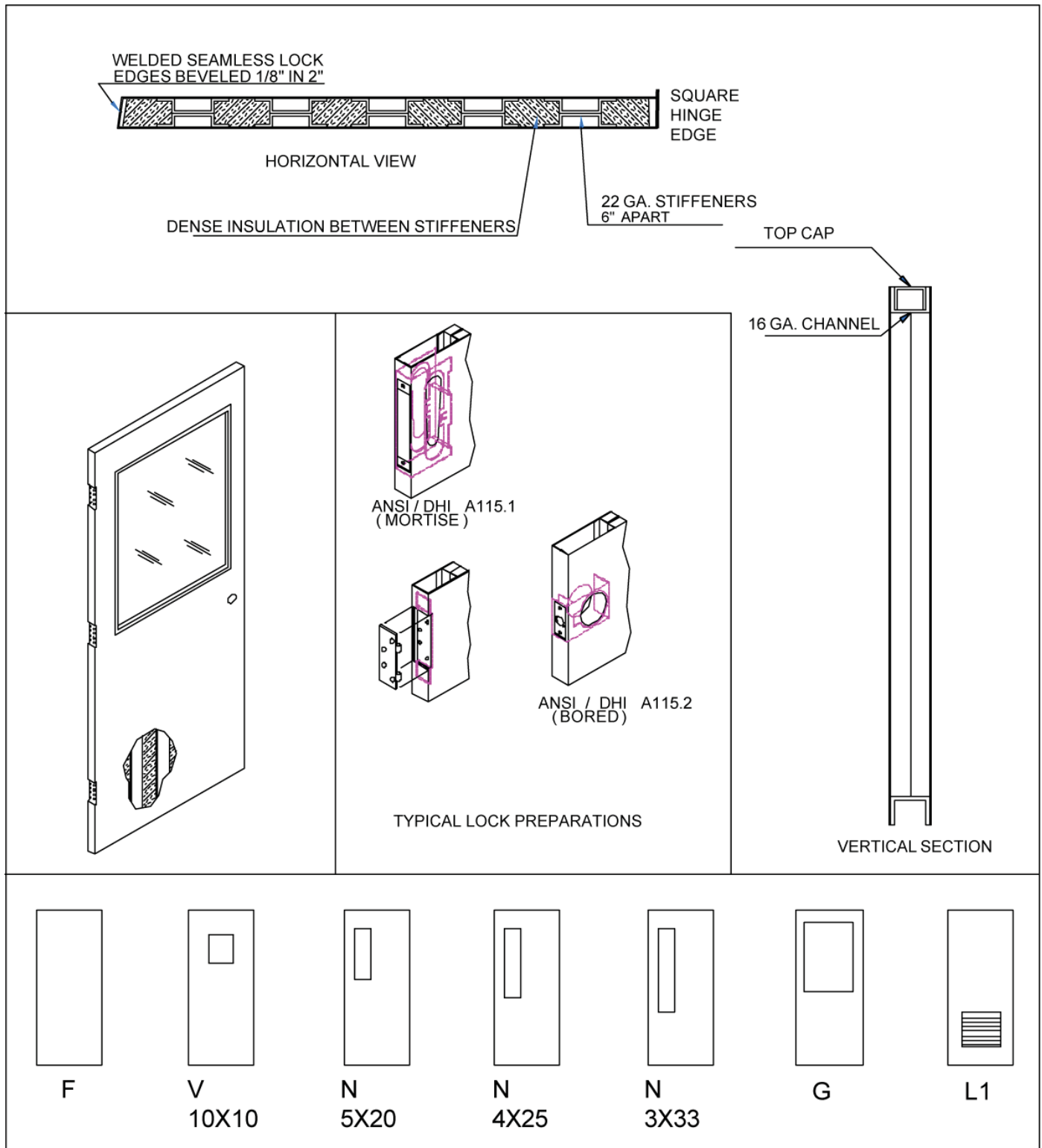

# 2000, 6000 Series 1 3/4" Honeycomb Core

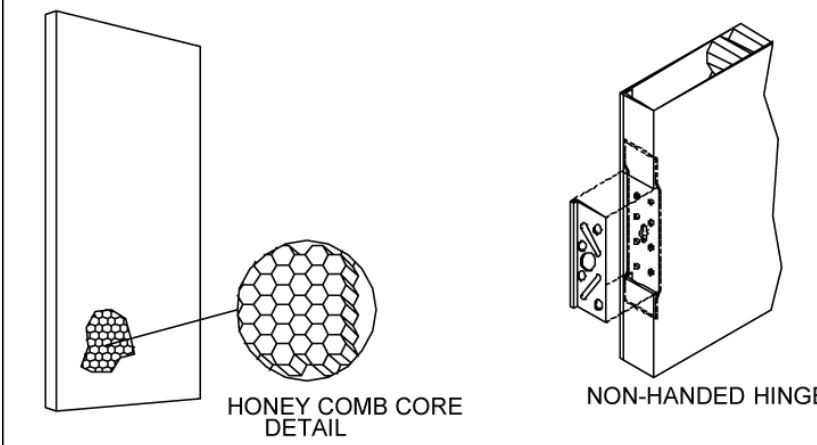
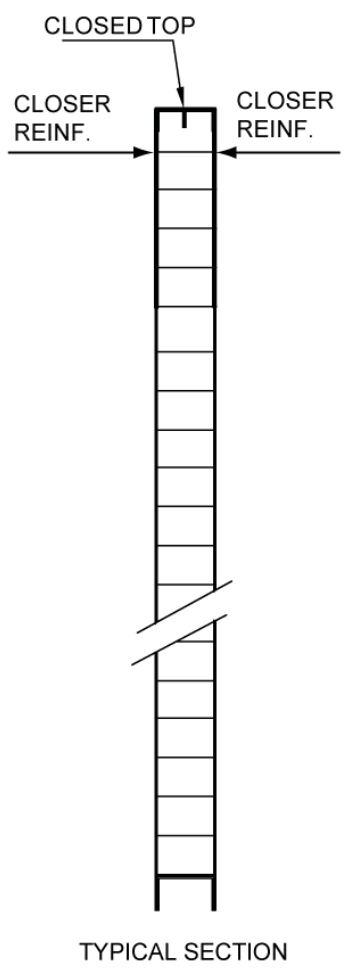
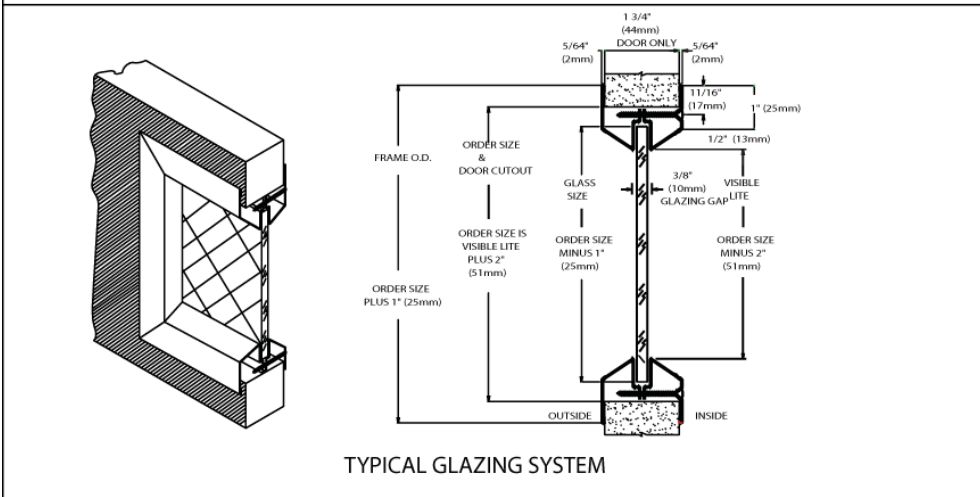
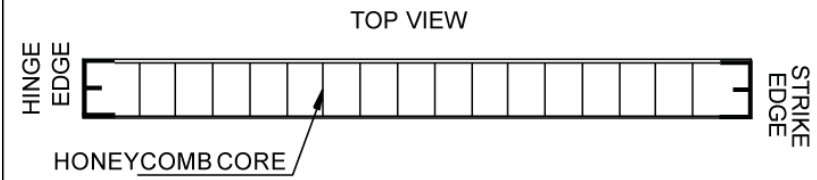

## 3 HR. LABEL STYLES



## 1 1/2 HR. LABEL STYLES

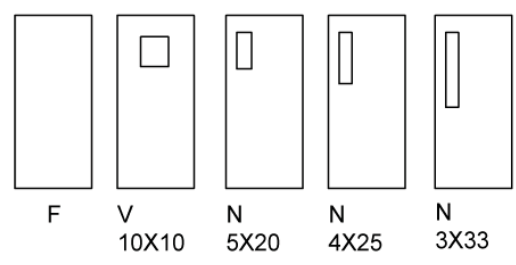

## 3/4 HR. LABEL STYLES

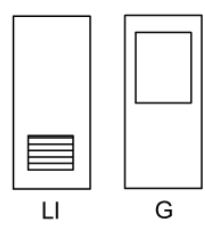

# 4000 Series 1 3/4" Masonry Frames

## FRAME PREPARATIONS

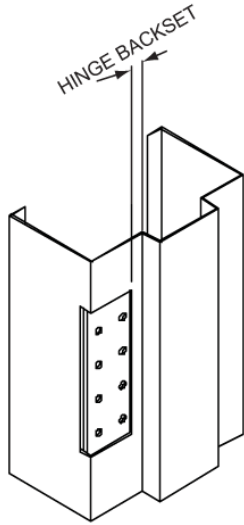

4 1/2" x 4 1/2"  
1 3/4" FRAME HINGE PREP

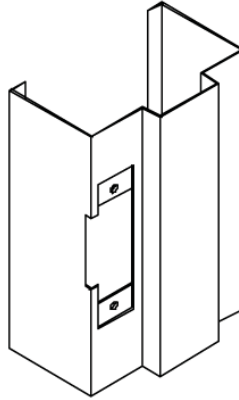

(4 7/8")  
UNIVERSAL  
STRIKE

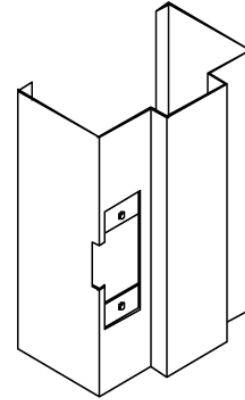

(2 3/4")  
CYLINDRICAL  
STRIKE

## FRAME PROFILES

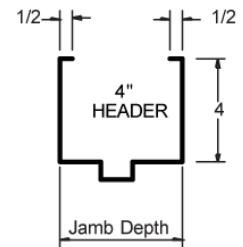
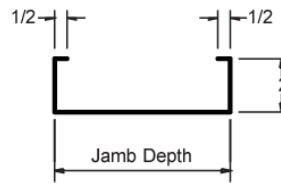
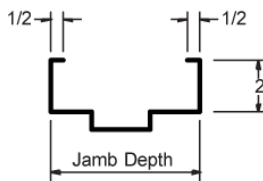
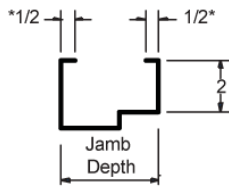

\* - 5/8" RETURNS ALSO AVAILABLE WITH A MINIMUM 1 3/4" THROAT

Note: 7/16" RETURNS ARE STANDARD WITH 5 3/4" DEPTH

## ANCHORS

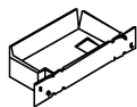

WOOD STUD ANCHOR  
(STANDARD)  
SPECIFY "WS"



WIRE MASONRY ANCHOR  
(STANDARD)  
SPECIFY "MA"

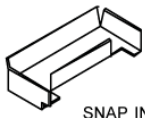

SNAP IN

STEEL STUD ANCHOR  
3 3/4", 4 3/4", 5 3/4"  
(STANDARD)  
SPECIFY "C"

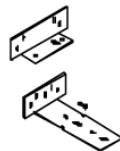

FLOOR ANCHOR  
(STANDARD)  
EXTENSION  
(OPTIONAL)

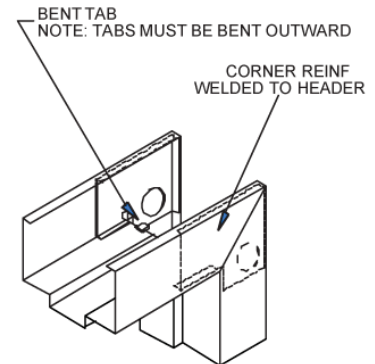

TYPICAL MITERED CORNER  
INTERLOCK FRAME SHOWN  
WELDED MITER CORNERS OPTIONAL



# 5000 Series 1 3/4" Drywall Frames

## FRAME PREPARATIONS

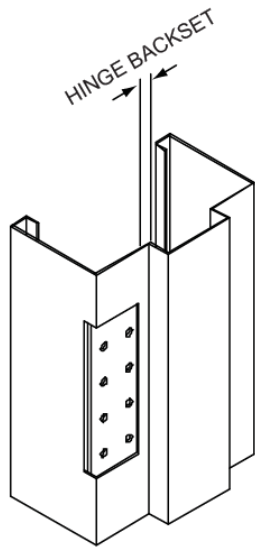

4 1/2" x 4 1/2"  
1 3/4" FRAME HINGE PREP

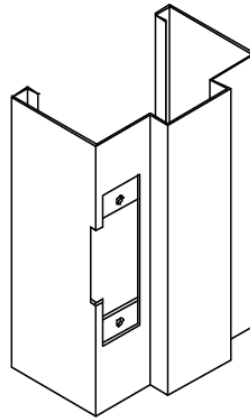

(4 7/8")  
UNIVERSAL  
STRIKE

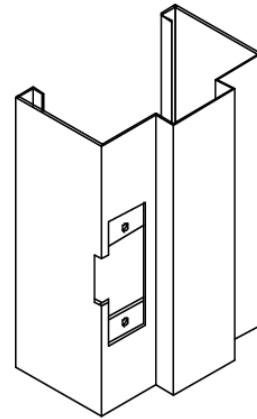

(2 3/4")  
CYLINDRICAL  
STRIKE

## FRAME PROFILES

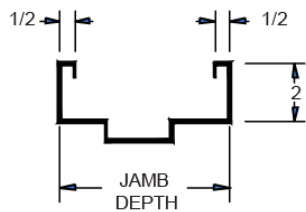

STANDARD 1 3/4" FRAME

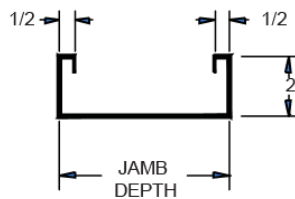

7/16" RETURN AT 7" DEPTH

CASED OPENING FRAME

## ANCHORS

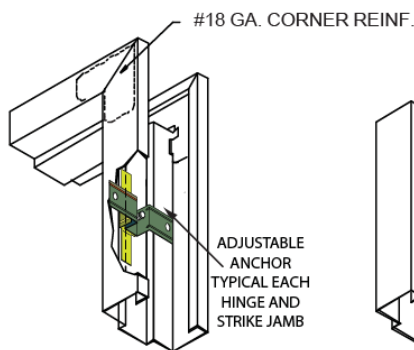

ADJUSTABLE ANCHOR

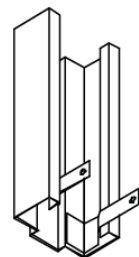

WELDED  
SILL STRAPS  
STANDARD  
(BASEHOLES  
OPTIONAL)

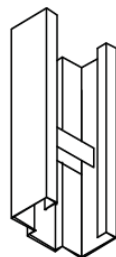

MIDDLE STIFFENER  
(WHERE REQUIRED AT  
FIRE RATED FRAMES)

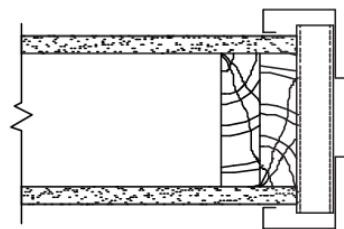

TYPICAL

WOOD STUD APPLICATION SHOWN  
ALSO APPLICABLE WITH:  
LAMINATED DRYWALL  
STEEL STUD WITH 1 & 2 PLY DRYWALL  
AVAILABLE STUD  
AND PRECAST CONCRETE.



# X4000 Expandable Masonry Frames

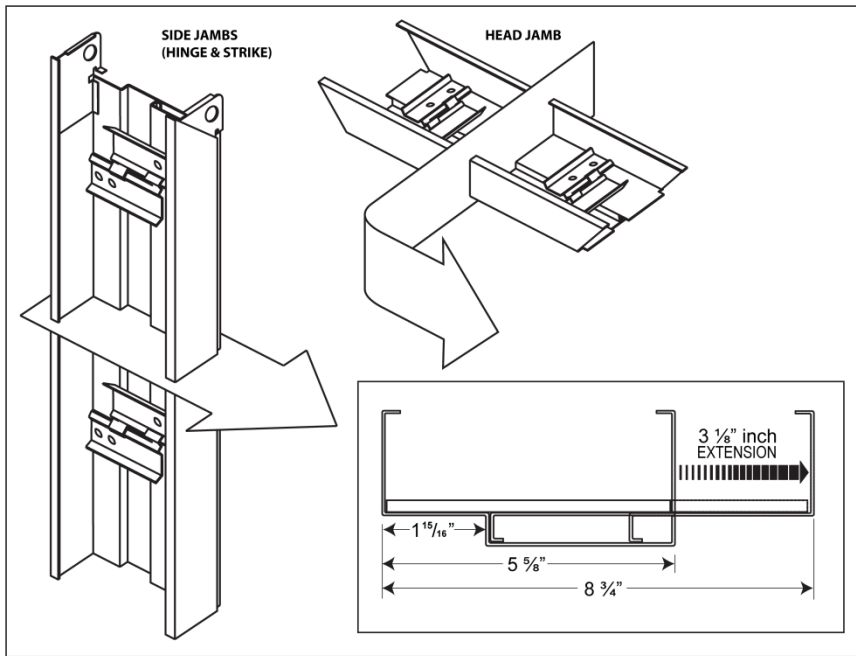

4-7/8" UNIVERSAL STRIKE

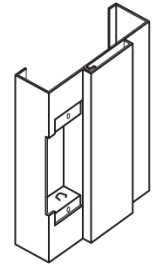
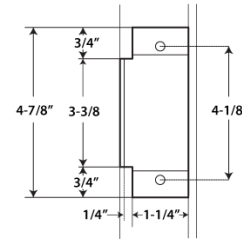

FRAME HINGE PREP

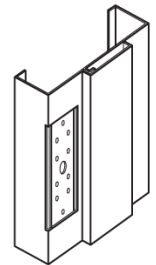
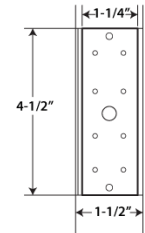

# X5000 Expandable Drywall Frames

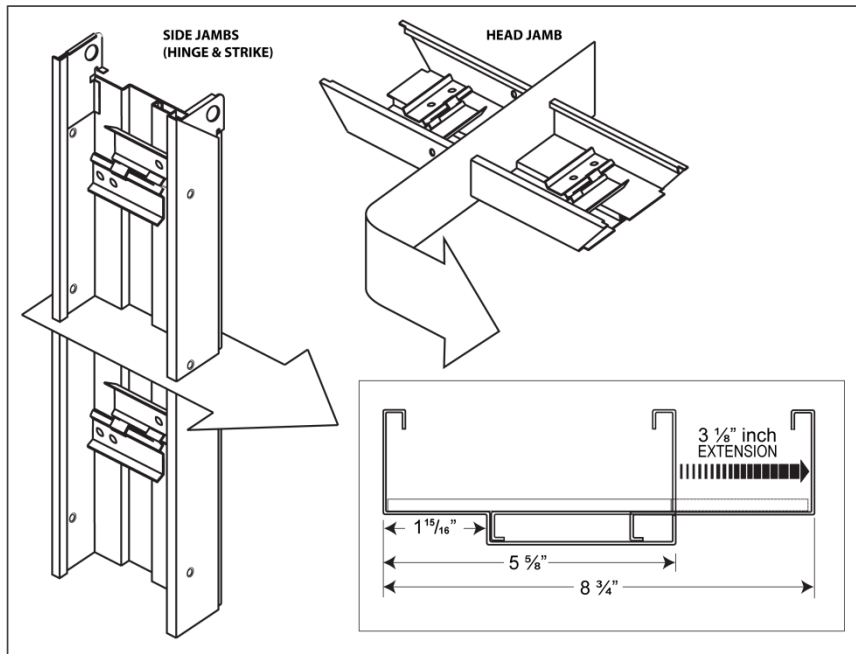

4-7/8" UNIVERSAL STRIKE

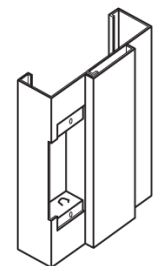
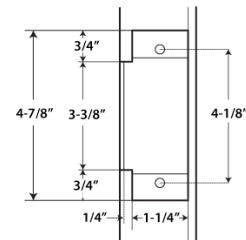

FRAME HINGE PREP

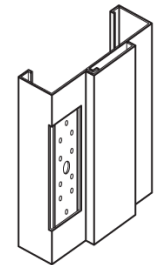
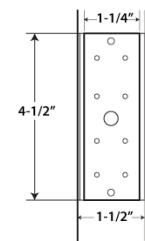



# 6000 Series 1 3/4" Double Egress Frames

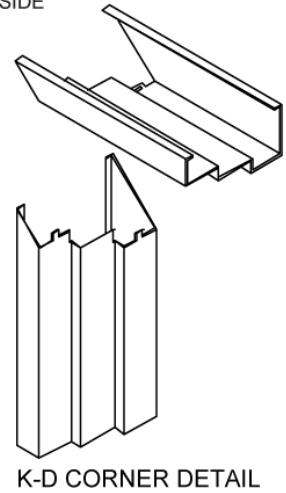
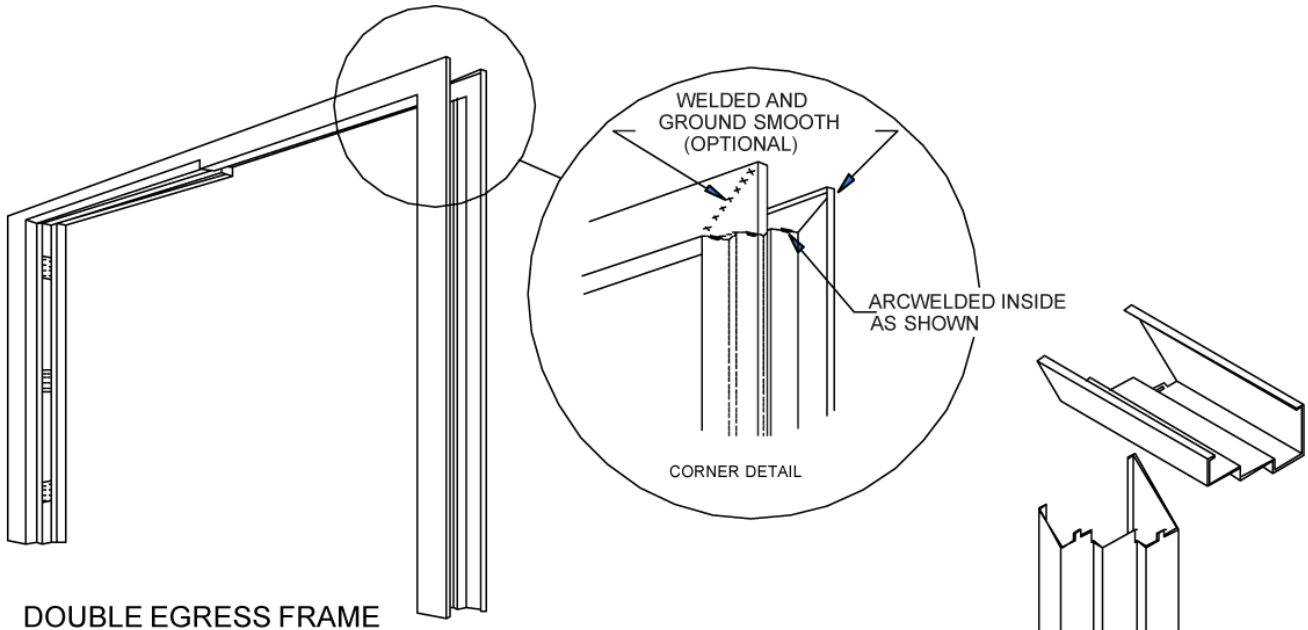

FRAMES PROVIDED RIGHT HAND EXCEPT AS NOTED

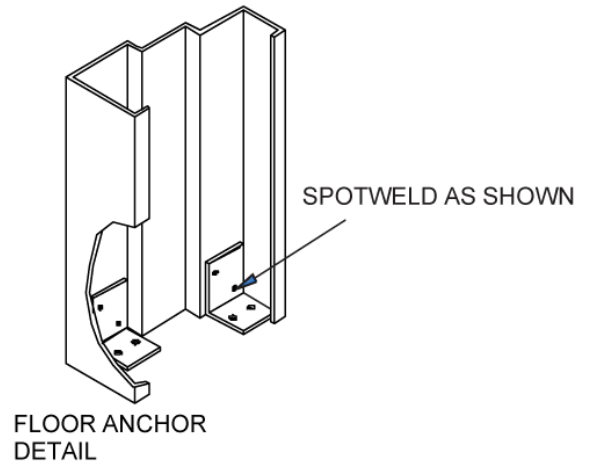
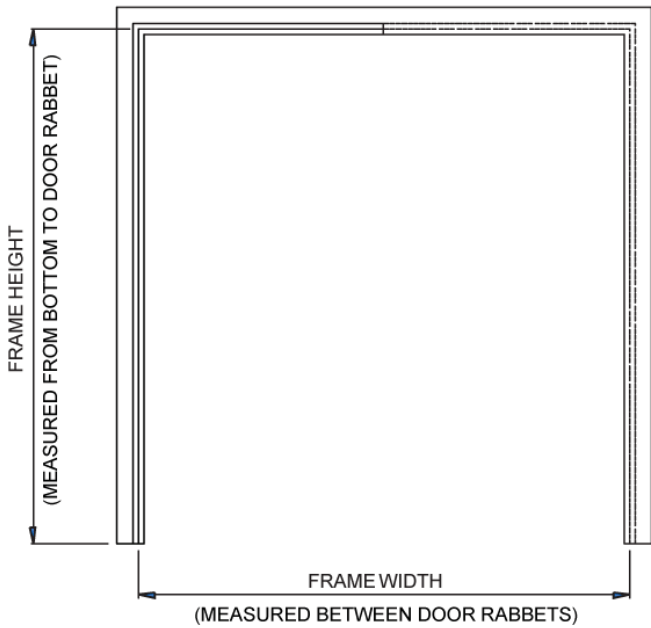
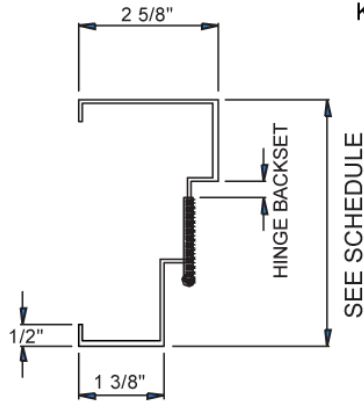
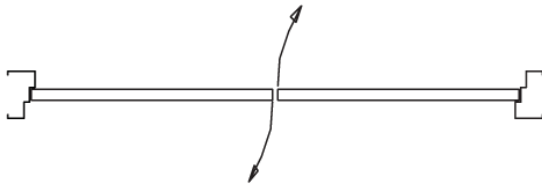

# 9000 Series 1 3/4" Doors

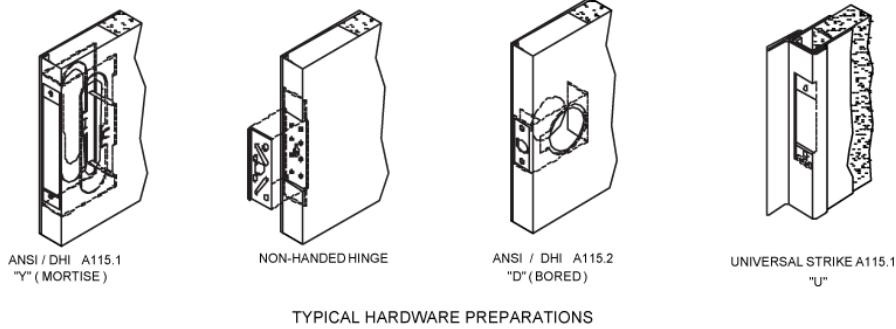
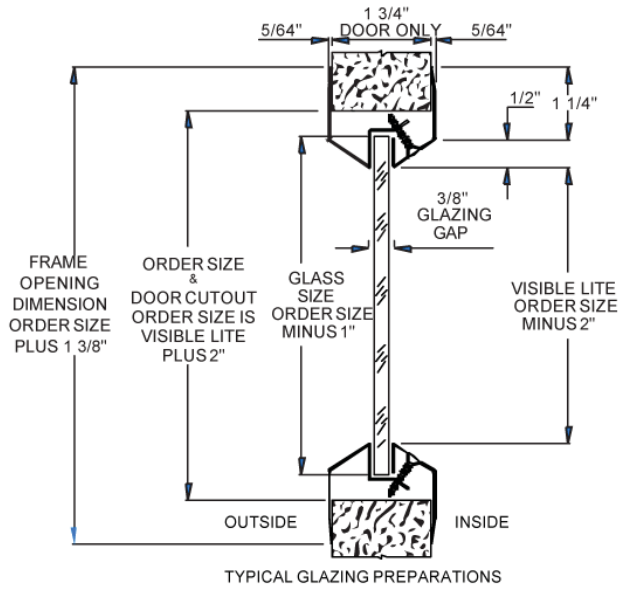
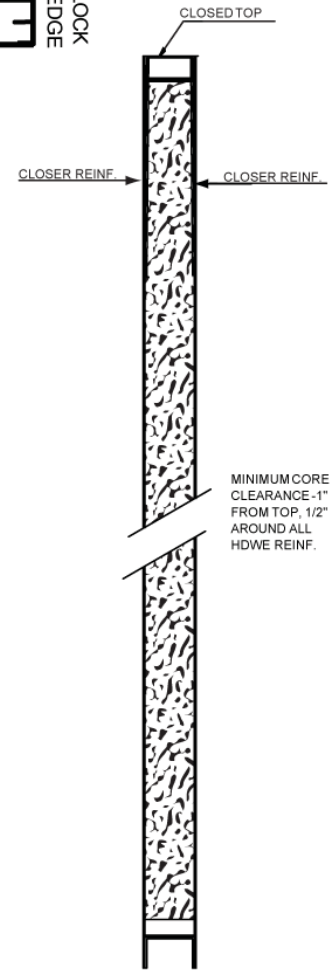
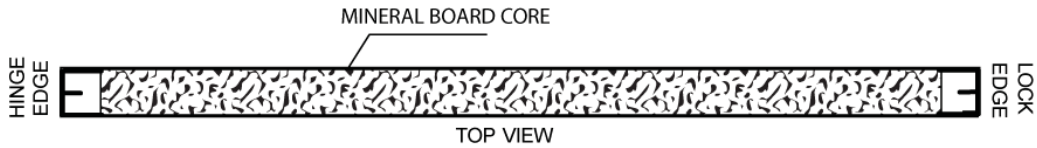

3 HOUR LABEL STYLES



1 1/2 HOUR LABEL STYLES



3/4 HOUR LABEL STYLES



# Drawing Page

